



Fractional Series (1/2HP)

5-in-1 Aerating Fountain & Mixer System

- ✓ 5-in-1 System Includes:
 - 4 Patterns & *Horizontal Mixer*
- ✓ 3 Year Warranty
- ✓ Corrosion Resistant Impellers
- ✓ 316 S/S Motor Housing
- ✓ As Shallow as 16in (41cm) Operating Depth
- ✓ Mixer Model Discharge Angle Adjusts +/- 8 degrees
- ✓ Oxygen Transfer Rate of 2.2lbs (1kg) per HP/hr with a Pumping Rate of 506GPM (115m³/hr) - Highest Performance Rate of any Fractional Aerator in the Industry*
- ✓ Deluxe Units Include LED 2-Light System and Quick Disconnect Cable Connections on both Unit and Lights
- ✓ Safety Tested & Approved; Listed with ETL, ETL-C and Carries CE Certification
- ✓ Ideal for Ponds 1/2 acre or Less

** Otterbine is the only manufacturer to publish performance results from independent 3rd party test facilities. Data provided by GSEE Environmental Consultants.*



High Volume

Phoenix

Rocket

Mixer

Gemini



Surface Spray Aerator
4 Interchangeable Patterns



Horizontal Mixer
Adjustable Discharge Angle



Visit Us Online to Learn More
or to Request a Quote!
www.otterbine.com/fractional_series



**COMPLETE WITH 4 PATTERNS
& HORIZONTAL MIXER!**

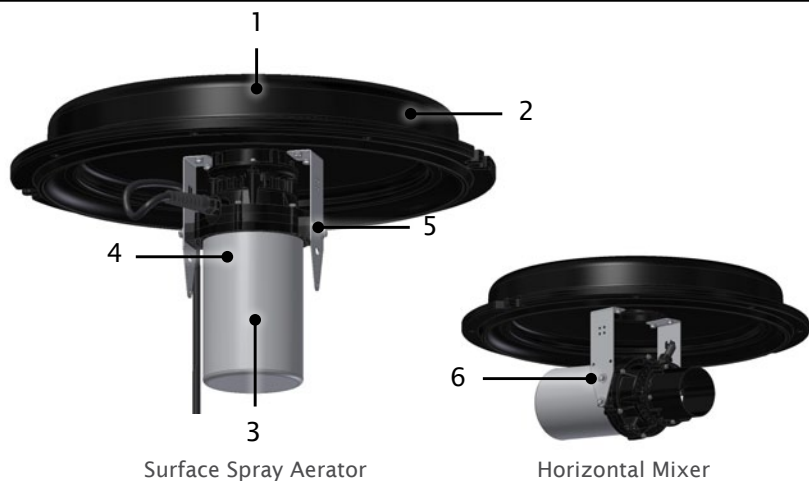

Manufactured by: Otterbine® Barebo, Inc. | 3840 Main Road East | Emmaus, PA 18049 U.S.A | PH: 610-965-6018



Fractional Series Deluxe with 2-Light LED Light Set, Quick Disconnect Cable Standard on Both Unit & Lights. Choice of Bright White (5700K) or Warm White (3000K) Lamps.

PRODUCT ILLUSTRATION



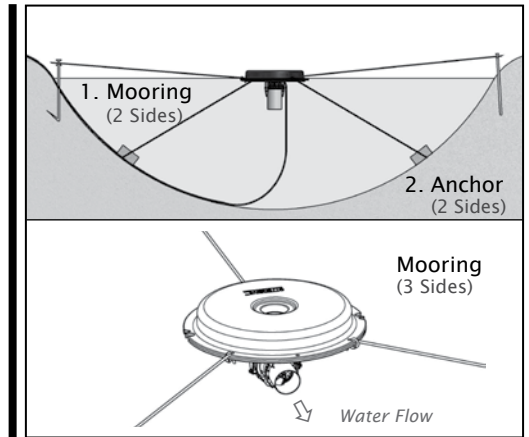

1. Includes corrosion resistant adjustable spray impellers/patterns to produce 4 spray patterns, and a horizontal mixer.
2. Rugged low visibility foam filled polyethylene float with recessed light pockets.
3. Oil cooled, efficient 3250RPM (60Hz) or 2750RPM (50Hz) custom built motor incorporates a silicon carbide single seal to ensure dependability and long life.
4. Corrosion resistant, durable 18 gauge/316 grade stainless steel motor housing.
5. S/S brackets allow for easy conversion between aerating fountain patterns and mixer model.
6. Adjustable discharge angle +/- 8 degrees. [Mixer Model only.]

The Fractional Series Deluxe features a low voltage 2-light LED light set with quick disconnect cable on both unit and lights. Max cable run on Deluxe units is 150ft (46m) with 16/2 cable & 300ft (91m) with 12/3 cable; contact factory for longer cable runs.

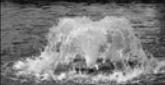

Installation Methods: (Top) Surface Aerator (Bottom) Mixer

1/2HP FRACTIONAL SERIES

Model	Motor RPM/Hz	Voltage/Phase	Running Amps	Spray Height	Spray Diameter	Pump Rate	Oxygen Transfer (HP/Hr)	Max Cable 12AWG/4mm ²
 Gemini	3250/60	115/1	5.6	4ft	4.5ft	506GPM	2.2lbs	300ft
		230/1	2.8					600ft
 High Volume	2750/50	230/1	2.8	1.2m	1.8m	115m ³ /hr	1.0kg	183m
		115/1	5.2					2ft
 Phoenix	3250/60	230/1	2.6	1m	1.4m	99m ³ /hr	.91kg	
		115/1	6.4					Upper: 10.6ft Lower: 3.8ft
 Rocket	2750/50	230/1	2.6	3m	40cm	41m ³ /hr	.36kg	
		115/1	6.4					10.6ft
 Mixer	3250/60	230/1	2.8	X		n/a*	n/a	
		115/1	5.6					300ft
		2750/50	2.6					183m

*1/2HP Mixer volume influenced is 245,000ft³ (6938m³) and effectively moves water 115 linear feet (35 linear meters).

Induced Circulation is 10X the Pumping Rate. Estimated shipping weight is 48lbs/21.8kg; this includes unit, power control center and 50ft (15m) of cable. (Power control center is optional on 50Hz units.) Minimum operating depth is 16in (41cm). Pumping rates may vary due to voltage, elevation and relative humidity. Specifications are subject to change.