

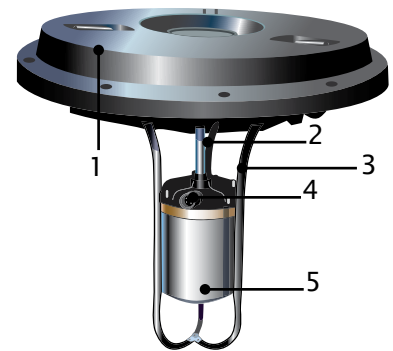

HIGH VOLUME INDUSTRIAL AERATOR

- » Highest oxygen transfer and pumping rates in the industry, moving 3.3lbs or 1.5kg of oxygen per horsepower hour, and pumping over 900GPM or 198m³/hr.
- » Quickly improves water quality and maintains cooler water temperatures than other surface aeration systems.
- » 3+5 year warranty. (3 yrs on moving parts, 5 years on non-moving parts.)
- » Operates in 40in or 1m of water.
- » Complete package includes assembled unit, power control center, and cable. (No PCC for 50HZ.)
- » Power control center comes standard with surge arrestor, timer and GFCI (Exc: optional EPD for 460V.)
- » Cable quick disconnect standard.
- » Safety tested and listed with ETL & ETL-C, conforming to UL standards; and carries a 3rd party listing with CE.
- » Ideal for managing the water quality of effluent and other high nutrient ponds.



PRODUCT ILLUSTRATION

1. Rugged closed cell foam filled low visibility polyethylene float.
2. Precision pitched stainless steel impeller is virtually unbreakable.
3. Protective arms secure motor unit and allow for easy handling.
4. Electrical disconnect is part of upper plate to prevent accidental damage.
5. Enclosed in a corrosion resistant, durable 18 gauge/316 grade stainless steel motor housing, the oil-cooled, efficient 1725/1425 RPM custom built motor has dynamically balanced rotors to move high volumes of water.

Minimum operating depth is 40in or 1m with and without lights. See www.otterbine.com for product testing and package details.

50 HZ	1 HP	2 HP	3 HP	5 HP
Spray Height (m)	.5	.6	.9	1.1
Spray Diam. (m)	1.2	2.3	2.6	3.5
m ³ /hr	198.5	329	453.1	647.2
Volt/Ph/Amp 1425@50hz	230/1/8	230/1/12	230/1/14 400/3/4.2	400/3/7.2

Product specifications and CADs can be found online through www.otterbine.com or www.caddetails.com